

SALES DRAWING SALES DRAWING SALES DRAWING SALES DRAWING SALES DRAWING

SALES DRAWING SALES DRAWING SALES DRAWING SALES DRAWING SALES DRAWING

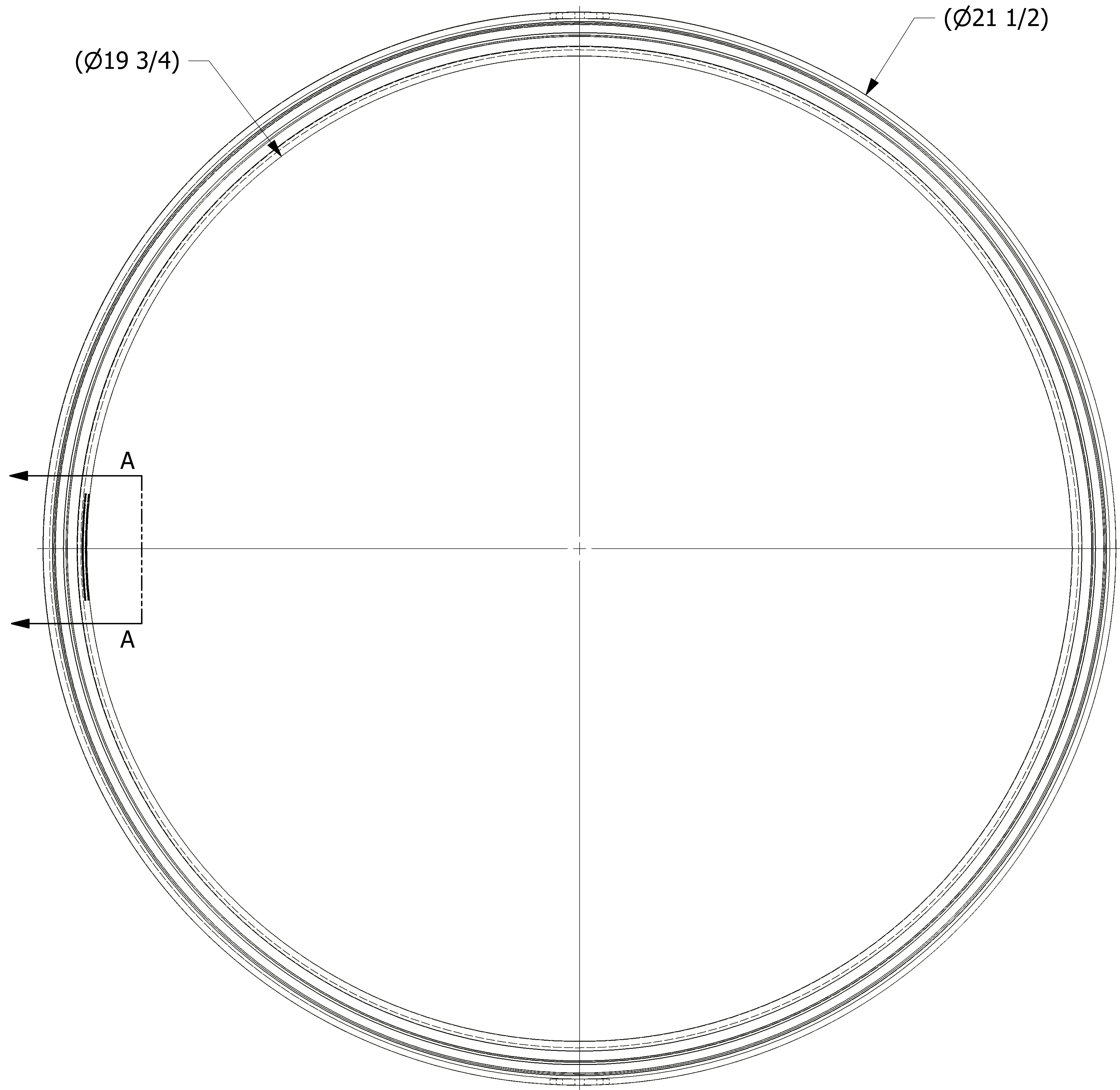

SALCO PRODUCTS	
PART # TC20BGNG02	
MATERIAL: NITRILE	
PATENTS:	
WWW.SALCOPRODUCTS.COM/LEGAL	

SECTION A-A
SCALE 3 : 1

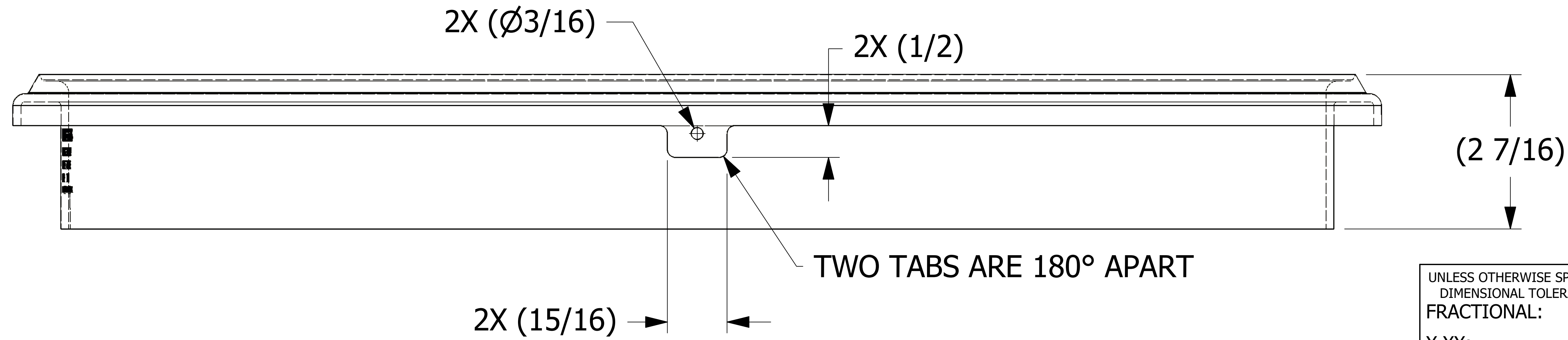

TWO TABS ARE 180° APART

UNLESS OTHERWISE SPECIFIED DIMENSIONAL TOLERANCES FRACTIONAL: ±1/16 X.XX: ±.03 X.XXX: ±.015 ANGULAR: ±1° DEBURR ALL SHARP EDGES. ALL MACHINED SURFACES TO HAVE A 125 RMS FINISH UNLESS NOTED OTHERWISE. THIRD ANGLE PROJECTION	DRAWN BY:	FOD
	CHECKED BY:	SAB
	PROTOTYPE DATE:	7/19/1999
	APPROVED FOR PRODUCTION BY:	SAB
	PRODUCTION DATE:	7/19/1999
	SIZE:	E
DRAWING #:	34319	

E	WEB	2/24/22	202202241301	WEB
REV	BY	DATE	REF #	PUB
		SALCO PRODUCTS, INC.		
PART NAME:		MANWAY NOZZLE GASKET 20"		
MATERIAL:		WHITE FDA NITRILE		
PROJECT #:		980623	SHEET #:	1 OF 1
PART #:		TC20BGNG02		
SCALE:		1:1		

THIS PRINT, PROPERTY OF SALCO PRODUCTS INC. CONTAINS PROPRIETARY INFORMATION AND MUST NOT BE COPIED, REPRODUCED, OR USED DETRIMENTALLY TO OUR INTEREST.